

# Dyna Booster

Stay on track.

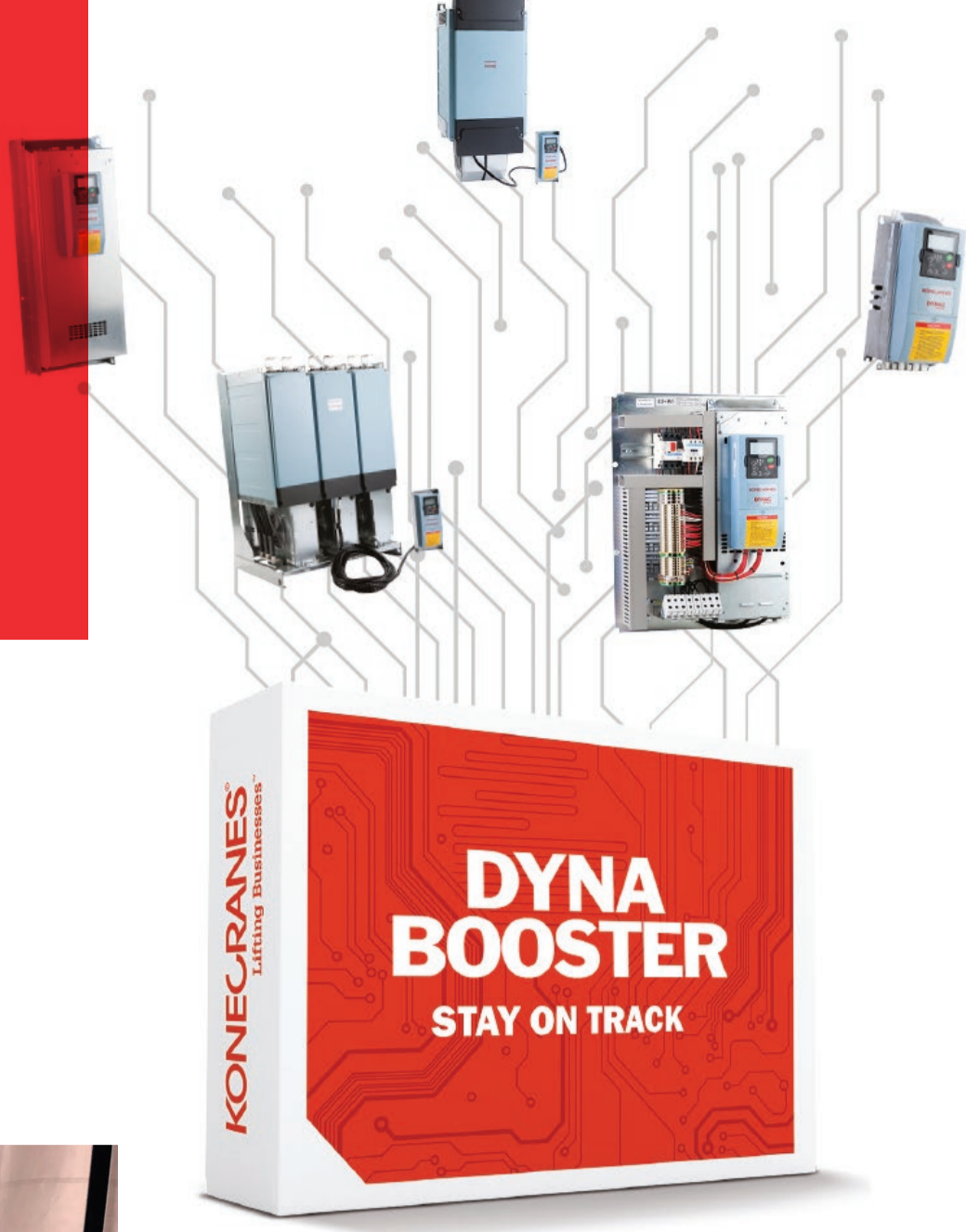

## ADAPT AND THRIVE

Konecranes is the premier **port services** provider to brownfield terminal developments. Our range of retrofit products will enable your fleet to adapt to a fast-changing environment. Welcome to your **evolution**. Small, incremental changes that enable existing fleets to continue to adapt and thrive.

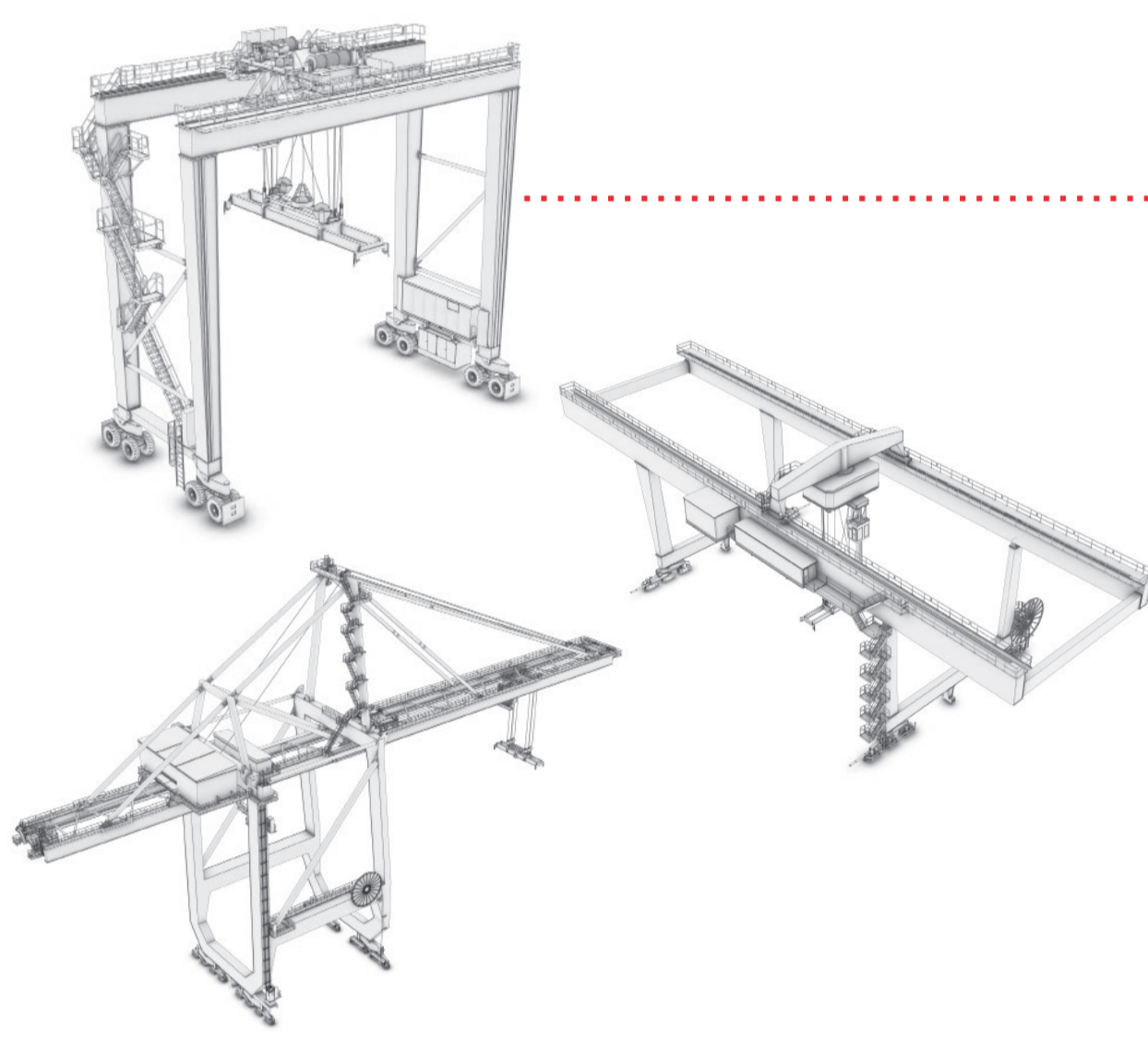

## EQUIPMENT

Dynaboster Lifetime Service can be applied to all **Konecranes** RTGs, RMGs and STSs.

**RTG**  
Rubber-Tyred Gantry

**STS**  
Ship-to-Shore

**RMG**  
Rail-Mounted Gantry



## BENEFIT

- Regular inspection and service of the complete inverter unit
- Extended inverter lifetime
- Reduces the risk of unexpected break downs
- Reliable Equipment Operation
- Less crane downtime
- Long-term cost savings

## HOW IT WORKS

- Regular maintenance is needed to ensure trouble-free operation and long life. Inverter cooling fans, electrolytic capacitors, circuit boards, fuses and brake control components are wearing parts and their failure will cause crane breakdown.
- Maintenance can be done at your site, or the inverters can be sent to the nearest **Konecranes** repair shop.
- There are three maintenance levels depending on the age of the D2V inverter.
- Each service level contains replacement of the mentioned components with original **Konecranes** spare parts, checking of the inverter connections, cleaning and maintenance reporting by a Konecranes specialist.

## D2V INVERTER BOOSTER REFRESH RENEW REBUILD

Recommended time period (in normal circumstances)	4 years	8 years	Option
New fan(s) or DC-fan retrofit	X	X	X
New DC-bus capacitors		X	X
New PC-boards			X
New current transformers			X
New IGBT transistors			X
New fuses			X
Checking of brake counter	X	X	X
Checking of wire / cable condition	X	X	X
Checking of main terminals	X	X	X
Cleaning	X	X	X
Fault history analysis	X	X	X
Functional tests	X	X	X
Load tests	X	X	X

**Ports. Evolved.**

**KONECRANES®**



Konecranes is a world-leading group of Lifting Businesses™, serving a broad range of customers, including manufacturing and process industries, shipping yards, ports and terminals. Konecranes provides productivity enhancing lifting solutions as well as services for lifting equipment of all makes. In 2020, Group sales totaled EUR 3.2 billion. The Group has around 16,600 employees in 50 countries. Konecranes shares are listed on the Nasdaq Helsinki (symbol: KCR)

© 2021 Konecranes. All rights reserved. \*Konecranes\*, 'Lifting Businesses' and  are either registered trademarks or trademarks of Konecranes.

This publication is for general informational purposes only. Konecranes reserves the right at any time, without notice, to alter or discontinue the products and/or specifications referenced herein. This publication creates no warranty on the part of Konecranes, express or implied, including but not limited to any implied warranty or merchantability or fitness for a particular purpose.